



THUNDERCAR RULES

** These rules may be amended at the official's discretion. **

No additions, subtractions, alterations, or non-OEM type parts allowed unless specifically allowed in the rules.
Visiting cars will be allowed to run at Tech Officials discretion.

- Models:** Stock off the street, American made, rear wheel drive, passenger cars as purchased from the factory with no modifications or alterations except as specifically allowed in these rules. No convertibles, trucks, jeeps, station wagons, etc. Wheelbase must not be less than 108". No Station wagons, Dusters, or other Uni-body cars unless the wheelbase is 112½" or more. Non-GM body, engine & transmission combinations may be used on a GM chassis; chassis components must be GM parts or direct replacement and are subject to the rules in section 13. **Wheelbase and track width must match car model. Maximum track width of 63½" for 108" wheelbase and 66" for 112" or greater wheelbase.**
- Body:** Bodies must remain stock appearing and reasonably match OEM dimensions. Any deviations must have prior Officials specific approval. All exterior trim, lights & lenses must be removed, and holes covered with minimum 24-gauge sheet steel. **All body panels may be steel or aluminum but must be stock appearing; nose and tail section may be plastic.** All cars must use the OEM stock roof with stock dimension 'A' & 'C' pillars. The AR Bodies Camaro/Challenger/Mustang body may be used on a GM metric 108" wheelbase chassis. All cars must meet side window dimensions. See drawing below. Maximum 5" tall side skirts may be aluminum. Side skirts must be within 10° of vertical. Aftermarket nose and tail must remain as manufactured and unaltered. **Aftermarket nose may be modified to allow for air flow to the radiator, adjustable nose skirt and brake duct holes only.** Body panels may be gutted. Altered interior allowed with 1/8" thick steel seat plate. Fixed side skirts allowed, provided they extend between the wheel openings and meet the ground clearance rule. No other aerodynamic devices allowed. Rub rails allowed on both sides of car with official's approval. The trunk floor may be removed. The hood must be secured with 4 hood pins near the front edge of the hood **and either 2 hood pins or hinges on the back side of the hood.** Hood scoops and fiberglass cowls are allowed provided that they remain non-functional and sealed to the hood and windshield. Fiberglass hoods may be used. **Fuel cell access panel must be a minimum of 12" front to back, and hinged or tethered at the front edge; no tools shall be used to gain access to fuel shut-off valve. No dishing, panning or altering of rear deck, fenders, quarter fenders, etc.... Rear deck must remain flat at all times.** 24-gauge steel **or aluminum** aftermarket panels are allowed. **Any repairs to exterior panels must use minimum 24-gauge sheet steel.** All interior plastic & fabric must be removed. All holes, from the trunk area to the engine compartment, must be sealed with minimum 24-gauge sheet steel. **Maximum spoiler height is 5" measured from the deck lid up and must be the same height the full length of the spoiler. Maximum surface area of the spoiler is 300 square inches. Spoiler must be single plane from the deck lid, centered on the car, and the ends of the spoiler must be at a right angle to the top.** Spoiler may be plastic or aluminum.
- Bumpers:** Steel tube front and rear bumpers are required. Bumpers must be centered at 19 inches from the ground, +/- 2inches.
- Glass:** All side and rear glass must be removed. A glass or 1/8" thick Lexan™ windshield of, approximate size, angle and configuration must cover the windshield opening. A Lexan™ windshield must have 2 vertical braces near the center to support the windshield. Rear windows and quarter windows may be covered with Lexan™. Quarter windows may be covered with minimum 24-gauge sheet steel. One interior rearview mirror, not to exceed 36 square inches, is allowed. A properly installed left door mirror is also allowed. No convex or multi-focal point mirrors. Door window openings must be totally unobstructed. See side window dimensions below.

5. **Roll Cage & Chassis:** A minimum 6 point properly installed roll cage of 1 3/4", .090.wall, and steel roll cage tubing is required. The roll cage must be securely fastened to the OEM frame. Minimum halo width is 35". Unibody cars must secure the cage to 10" X 10" X 3/16" sandwich plates bolted through the floor. The main hoop must be located behind the driver and extend as close to the roof and sides of the car as possible. The main hoop must be braced from the top, down and back, to the frame. Some type of 'X' bracing must be installed between the uprights of the main hoop. A minimum of 4 left side door bars must be installed. 2 vertical bars must be installed between each level. Left side door bars and foot area must be fully plated with 1/8" steel. A minimum of 3 door bars, or an 'X' must be installed on the right side. These door bars do not have to follow the contour of the body provided there is a rub rail support bar installed. No bars may extend beyond the contour of the car body. No use of pipe fittings, weld ells, square tubing, exhaust pipe, etc. All welding must be done with an electric welder. All cages will be inspected for quality of construction. Roll bar padding, within reach of the driver, is mandatory. The chassis must remain stock forward of the rear axle. The rear frame rails may be replaced with 2" X 3" X .090" steel tubing from the centerline of the rear axle back. Front frame clip may be replaced with a DCA clip. DCA serial number required.

6. **Engine:**

A. **Standard Engine:** Blocks and heads must be OEM mass-produced stock, cast iron, street applicable only. No high performance or special heavy-duty blocks or heads. No removal or addition of metal to any part unless specifically allowed as follows. Main bearing saddles may be line bored, rotating assembly may be balanced, valve seats may be ground for a stock type 3-angle valve job with no angle greater than 75°, heads and deck may be machined to improve sealing but stock angle must be maintained, and rocker arm stud bosses may be machined for screw-in studs and guide plates. Stock type rods may have cap screws and polished beams. No H-beam, titanium or aluminum rods. No spacers between heads and intake manifold, or heads and block. 1 head gasket per head. Maximum displacement is 350 CID plus .060" overbore for GM, 351 CID plus .060" overbore for Ford and 360 plus .060" overbore CID for Mopar. **Maximum displacement 362CID. (Chrysler products 368CID)** Engines over max CID will not be allowed. Stock type steel or cast iron crankshaft only with no modifications except for balancing. No knife-edge or light weight crankshaft allowed. An oil pan inspection hole required, must be located on the driver's side in line with the 2nd or 3rd rod journal, or crankshaft, with a 3/4" NPT inspection hole in pan on opposite side of windage tray. Stock bore/stroke configuration only. Stock firing order only. Compression ratio may not exceed 10.8:1. Ford may not use 4V Cleveland heads, Mopar may not use W-1 or W-2 heads, GM may not use Turbo, angle plug or Bowtie heads. Vortec heads are allowed on small block Chevy engines. Stock valve stem size for heads. Stock type rocker arms only. Chevy engine may use 1.5:1 ratio aluminum roller rocker arms. **Ford Engine may use stock ratio roller rocker arms for motor and heads.** No shaft type roller rocker arms. No rocker stud girdles. Valve springs must be stock type and may not be oversized. Oil feed lines to the valve covers not allowed. Flat tappet camshaft and hydraulic lifters only. No large diameter or 'mushroom' type lifters. Maximum valve lift is .500". Vortec heads, #060, #062 or #906, allowed with maximum valve head size of 1.94 intake, and 1.50 exhaust. EngineQuest Vortec replacement head, part # CH350C is allowed with no modifications. Intake manifold, all makes and engines must use Edelbrock 'Performer' or Edelbrock 'Performer RPM' with no modifications. All engine parts must be Ford-to-Ford, GM-to-GM, and Mopar-to-Mopar. Absolutely no coatings of any type to the internal surfaces of the block, heads, intake manifold, exhaust manifold, and exhaust pipes. **All engines must be located so that the furthest forward spark plug is in line with or ahead of the lower ball joint's centerline. Minimum crankshaft centerline height 10.5" (front and back). Maximum offset (right-left) 1".**

B. **602 GM Crate Motor:** Must be purchased NEW from a GM dealer. Motors may NOT be rebuilt or repaired. Inspection plug in the oil pan is mandatory. Only Murgic's Auto is authorized to perform this work and will reseal the pan with their seals. Any new Crate engine purchased after 2018 season, oil pan inspection plug not required. MSD Soft Touch rev control, part #8727CT must be used. Max 6400 RPM. Box must be mounted within 16" of the passenger window opening, and read out must face passenger window opening. MSD factory wiring harness must be used and wired directly to the distributor. **Pump premium fuel only. Fuel must meet the properties of the track fuel. NO RACE FUEL.**

50 pound weight break with a Crate Motor; percentages will remain the same.

Valve spring and rocker arms may be replaced as maintenance items, and must be GM OEM per 'Circle Track Crate Engine Technical Manual'.

Holley 650HP series 4150, part #80541-1 only.

1. Must be as manufactured.
2. Re-jetting is allowed.
3. All parts must be Holley OEM.

One carb base gasket, maximum of .250" thick, must have four holes maximum of 1.8" bore, no open plenum gaskets allowed. NO spacer plates allowed. Schoenfield headers, part #135 or #145 only as manufactured. No coatings, heat wrap or merge-collectors.

7. **Electrical:** 12-volt electrical system only. The battery must be securely mounted behind the driver. A clearly marked master disconnect switch must be installed behind the driver's seat and be easily operated from outside the vehicle. OEM factory stock distributor ignition system only. Open type module may be used, but it must fit inside the distributor. **No rev limiting devices allowed on built engines.** No MSD, or similar, ignition systems. Self-starter must be in good working order.
8. **Cooling System:** A minimum 2-quart overflow can must be securely installed in the engine compartment. Only water may be used in the cooling system. A fan shroud must cover the top ½ of the fan. Radiator cooling fan must be belt driven with the water pump. Full air box allowed for radiator cooling.
9. **Exhaust:** Stock cast iron exhaust manifolds only with no modifications. No Corvette center dumps or other high performance exhaust manifolds. Exhaust manifolds must be GM-to-GM, Ford-to-Ford, etc. Dual exhaust system only. Left and right exhaust pipes may not be connected together in any way. Exhaust pipes may be a maximum 2 ½" outside diameter. The exhaust must exit behind the driver. Exhaust may exit the right side door. ~~Some type of functional mufflers is required.~~ Turndowns at the rear of the muffler may be no more than 4" long.
10. **Fuel System:** A clearly marked fuel shut-off valve must be installed near the fuel cell. Fuel line and vent line must exit from the top of the cell. No fuel lines may run through the driver's compartment. Stock type mechanical diaphragm fuel pump only. No fuel pressure regulators between the fuel pump and the carburetor. **Fuel must meet the properties of the track fuel.** A Holley 500 cfm 2-barrel carburetor model #4412 only with no modifications except as follows: Jets, accelerator pump diaphragm & cam, and power valve may be changed; the choke butterfly & related linkage may be removed; idle holes may be drilled in the throttle butterflies; E85 carb may use a billet metering block. The Keith Dorton 500 cfm carburetor # 0-80583-1 is allowed. Carb spacer max thickness 1.625" including gaskets straight bore full height. Flat on top flat on bottom 2 main holes **1.80"** diameter max any material. No cold air boxes. Carb hats are allowed.
11. **Fuel Tank:** A maximum 8-gallon fuel cell is required. The fuel cell must be mounted to the rear frame rails with minimum 1" square tubing, **centered between the frame rails.** The fuel cell must maintain 10" ground clearance. A fuel cell protection bar must be installed behind the fuel cell made of 1 ¾" .090 steel tubing.
12. **Drive Line:** Any stock automatic transmission allowed, GM-to-GM, Ford-to-Ford, etc. All forward gears and reverse must work. Functional torque converter only with a minimum diameter of 10". No direct drive or lock-up type torque converters. **A manual stock OEM transmission will be permitted. Manual transmissions must utilize stock all magnetic steel type pressure plate and magnetic steel or cast-iron flywheel (min 15.5lbs.). Clutch disc must be a minimum of 10" diameter with stock full fiber disc. All gears must be operable, maximum 4 forward gears/ 1 reverse. No straight cut gears or gun-drilled main shafts, no lightening of gears on main shaft. Steel, 2 ½" minimum diameter, drive shaft must be painted white. 1 driveshaft safety hoop is required approximately 12" behind the transmission. OEM stock passenger car rear axle only for make & model of car. No aftermarket rear-ends housings allowed. Locked or open differential only. C-clip eliminator replacement carriers are allowed. No torque sensing, limited slip or locker type differentials. No cambered rear ends. Ford 9" allowed, unlocked or locked by welding or spool only. Magnetic steel spools only. If using 9" Ford rear-end, upper control arm mounts on frame may be raised a max of 1", lower control arm mounts on rear-end will only be allowed to run in stock location. All cars will be allowed to use a floater type rear end.**
13. **Suspension:** **Stock unmodified upper and lower rear control arms and stock unmodified front lower 'A'-arms only. Front upper 'A'-arms must be non-adjustable, all steel, one piece design, with stock type shaft and mount points. Left front lower 'A'-arm may not be used on the right side, and right front lower 'A'-arm may not be used on the left side. Lower 'A'-arms must match chassis. Stock-type re-buildable ball joints allowed. Any stock spindles may be used, but must be GM-to-GM, Ford-to-Ford, etc. Urethane bushings with no offset may be used. All other components must remain stock and in stock locations, except where otherwise stated. Springs may be minimum 5" diameter racing springs. Screw jacks allowed on all 4 corners. No remote suspension adjusting devices. Stock type sway bar may be mounted below the lower 'A'-arms. No part of the rear sway-bar system may remain in the car. Shock Absorbers allowed: QA1: 50, 51 & 26 series, Pro: TA, AFCO: 10 series (blue) & Carrera: 31 series, Old white AFCO's and Pro WB's. Only one shock absorber per suspension corner. Front shocks may be located outboard. Rear shocks must be mounted both in front of, or both behind, the rear axle housing. No other use of heims in the suspension. No bump-stop or coil-bind suspension systems. **No bump stops/rubbers, compression or rebound limiting, coil-bind coil spring devices allowed. No travel limiting devices such as chains, bolts, straps, etc. Rear axle droop chains are allowed with a minimum of 3" of quarter panel travel before the tire comes off the ground when the frame is jacked up.****

14. **Steering:** OEM stock manual or power steering box only. No ratio multipliers. Aluminum tie rod adjusting sleeves allowed. 5/8" heim joints may be used for the outer tie rod end. Steering shaft may be aftermarket, but must be collapsible, and/or use 2 u-joints. Heim joints may be used in steering column only. Steering wheel may be removable, and the center of the steering wheel must be padded. All steering parts must be OEM equivalent for the chassis, unless otherwise noted.
15. **Brakes:** Front and rear brakes may be disc or drum. No aluminum brake drums. Howo or OEM, stock type, cast iron, single piston brake calipers only. One stock type master cylinder only. One brake bias adjuster allowed. All brake pads must be functional. One 3" cold air brake duct allowed per side on front brakes, must enter through the nose and be pointed at the calipers only. No electric brake blowers or 'rotor fan' plates. Aftermarket steel front rotors and hubs allowed. Steel braided hose allowed from the caliper to the steel hard line.
16. **Tires:** Track tires only. (See separate tire rule.) No use of tire softener or altering of the tires in any way.
17. **Wheels:** Steel racing wheels are required. 8" maximum wheel width. 2" minimum offset measured from mounting face to bead flange. 1" lug nuts are required on all wheels. 5/8" studs allowed. No wheel spacers.
18. **Weight & Height:** Minimum weight is 3100 LBS. with driver in the car. Weight penalties may be assessed on a case by case basis for unusual circumstances. Front weight must be at least 52% minimum. Left side weight must be a maximum of 58%. All ballast must be painted white, and have your car number on them. No piece of ballast may be less than 5 pounds. All ballast must be securely mounted to the frame or roll cage only. No ballast may be in the driver's compartment. All weights will be checked on the race track scales with the driver in the car. All cars ground clearance is 4³/₄" except for suspension and exhaust components, this includes aftermarket nose and side skirts.
19. **Seat:** Aluminum racing seat only. No plastic, fiberglass, or carbon-fiber seats. 1" square tubing may be used for the seat support structure and seat belt anchoring. The seat support structure must be attached to the roll cage and frame only.
20. **Safety:** A driver's window net is required. A fully charged fire extinguisher, securely mounted, within the drivers reach, is required. See also General Rules for additional safety equipment requirements.

Amendments:

Thundercar

GM Body Dimensions

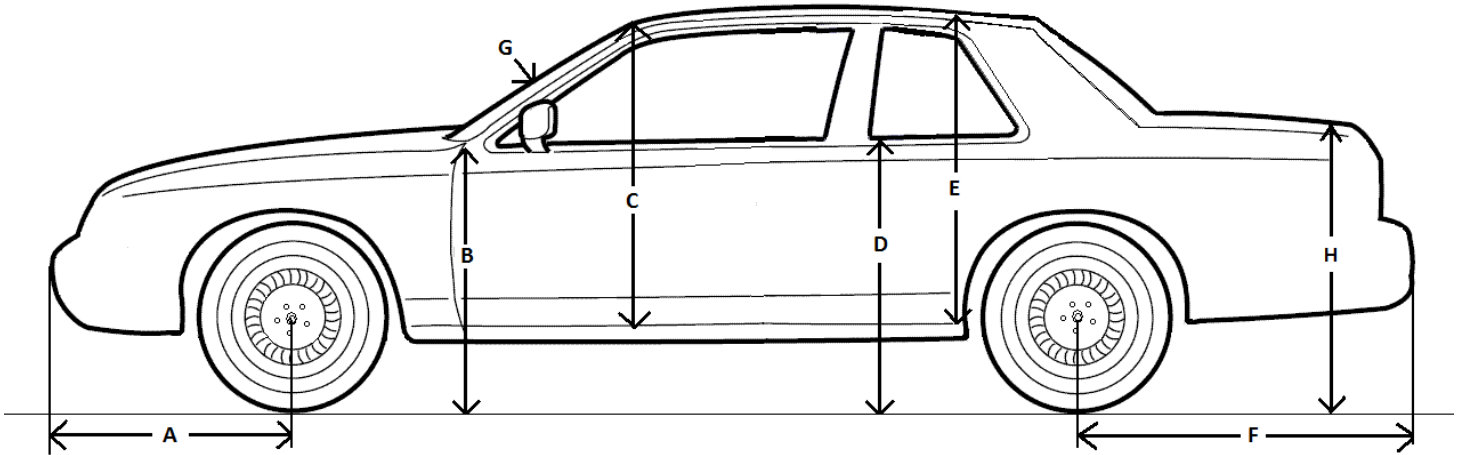

- A Centerline of front wheels to forward most point of front bumper.
- B Rear top edge of fender to ground. (at raceheight)
- C Roof height, at front edge, to top of framerail.
- D Front top edge of quarter panel to ground. (at raceheight)
- E Roof height to top of framerail.
- F Centerline of rear wheels to rear most point of rear bumper.
- G Windshield angle. (+/-2°)
- H Deck Height.

Leading edge of splitter to front edge of bumper = 2" max.

	GM Mid-size Car	GM Full-size Car
A	33"	35"
B	34"	34"
C	35"	35"
D	34"	34"
E	37" (15" forward of rear window edge.)	37" (2" forward of rear window edge.)
F	53"	49"
G	30°	30°
H	36.5"	36.5"

Note: These measurements are at 4" ground clearance. Adjust height dimensions for your ground clearance.

Side Window Detail

All cars except Camaro/Challenger/Mustang

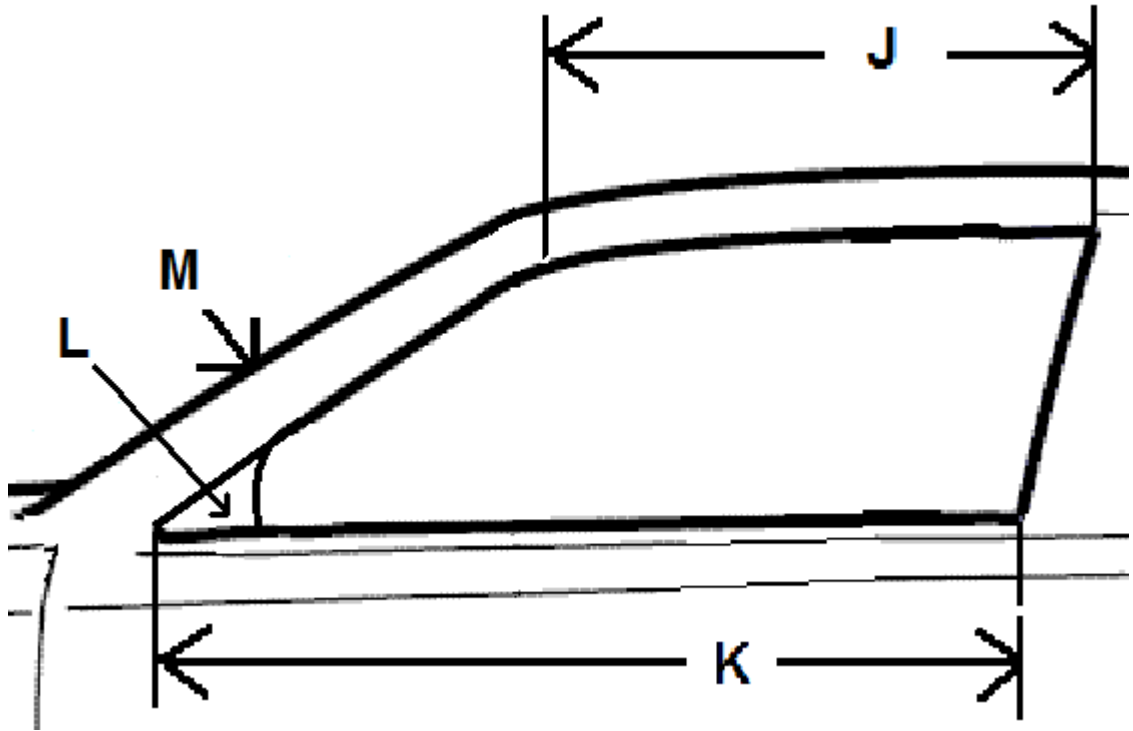

J	Window opening – top.	31" Minimum
K	Window opening – bottom.	41" Minimum
L	Front lower window gusset.	5" wide X 5" tall Maximum
M	A-pillar width.	4" Maximum

Metric Camaro/Challenger/Mustang Body Dimensions

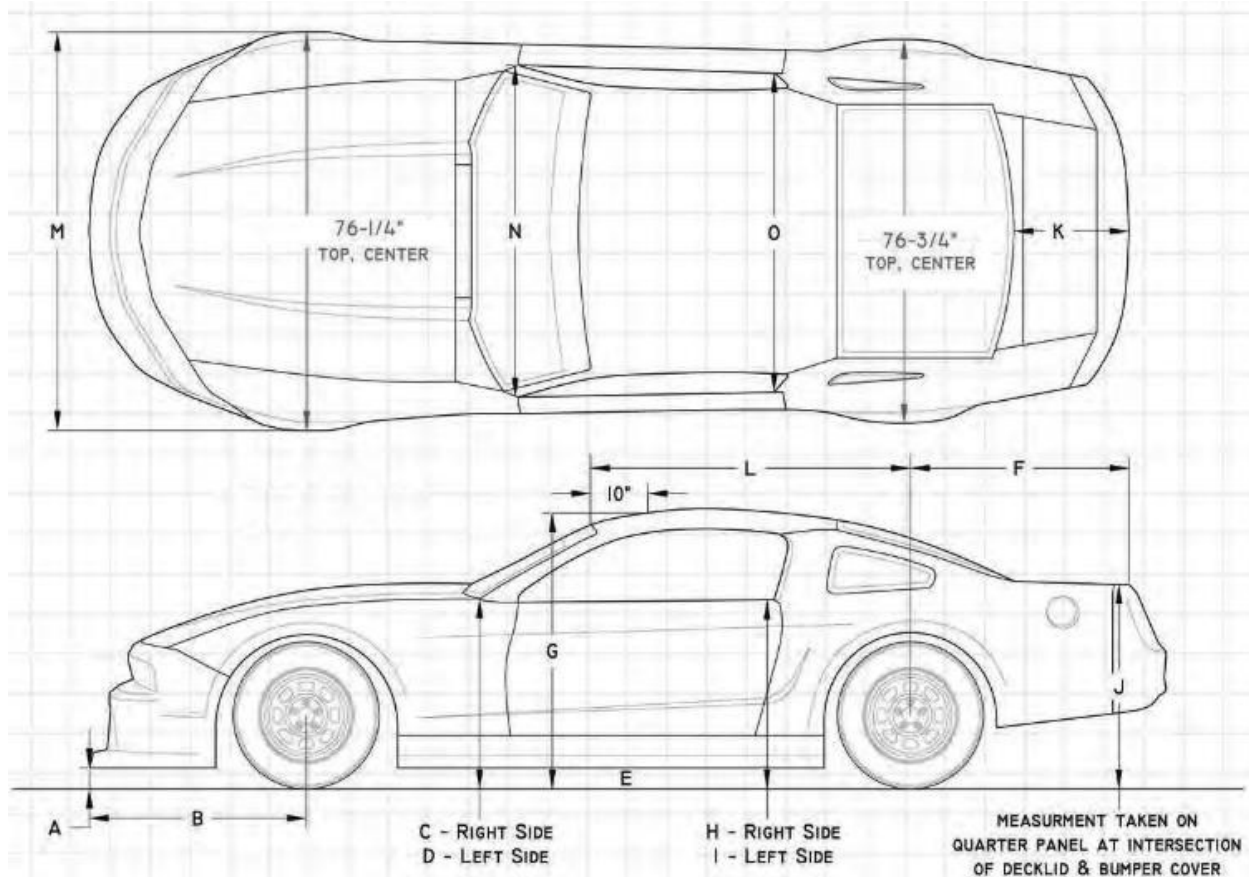

A.	NOSE HEIGHT (MIN): from ground to bottom of nose	4 3/4"	I.	DOOR HEIGHT: LEFT at rear	33"
B.	FRONT OVERHANG (MAX): on centerline	46 3/4"	J.	QUARTER PANEL HEIGHT: at bumper cover/decklid intersection	35 1/2"
C.	FENDER HEIGHT: RIGHT at front of A-post from ground	32 1/2"	K.	REAR DECK: at center, from base of spoiler to rear window	21 1/2"
D.	FENDER HEIGHT: LEFT at front of A-post from ground	32 1/2"	L.	FRONT OF ROOF TO CENTER OF REAR AXLE:	56"
E.	SIDE PANEL CLEARANCE (MIN): from ground	4 3/4"	M.	BODY WIDTH: at wheel wells	78 1/2"
F.	REAR OVERHANG (MAX): from base of spoiler at centerline to axle center	44 1/2"	N.	DOOR TO DOOR WIDTH: FRONT at "A" post and inside edges of the doors	66 1/2"
G.	ROOF HEIGHT (MIN): 10" back from windshield, on centerline	48"	O.	DOOR TO DOOR WIDTH: REAR at "B" post and inside edges of the doors	64 1/2"
H.	DOOR HEIGHT: RIGHT at rear	33"			

Note: These measurements are at 4" ground clearance. Adjust height dimensions for your ground clearance.